

# RIDER MANUAL

URTOPIA CARBON E-BIKE





**Inspire Passion,  
Activate Life**

# TABLE OF CONTENTS

## English

BEFORE YOU READ	4
ASSEMBLE YOUR E-BIKE	6
USE YOUR E-BIKE	13
RIDE: SAFE & FUN	15

# BEFORE YOU READ

This manual contains critical details about how to safely operate and maintain your Urtopia Carbon E-Bike. Read it carefully and familiarize yourself with it before riding. Pay special attention to the safety messages shown here.

Riding any bike or other vehicle always involves some risk of serious injury or death. Your safety depends on many factors including your bike knowledge, your bike's maintenance, road safety & warnings, etc. There are also factors we cannot control or anticipate in every situation or condition while riding. This manual makes no

representations about the safe use of bikes under all conditions. If you have any questions you should contact Urtopia immediately.

Assembly and adjustment of your Urtopia Carbon E-Bike require special tools and skills. Keep this manual and any other documents that came with your Urtopia Carbon E-Bike. All information in this manual is subject to change or withdrawal without notice. Visit [www.newurtopia.com](http://www.newurtopia.com) to view and download the latest version. Urtopia makes every effort to ensure the accuracy of its documents including this manual.

## Assembly Tutorial Video on App

Download the app and watch the specially-made tutorial FIRST before assembly. Strongly recommended!



Scan to download the Urtopia app



Screenshots of assembly tutorial



# Inside the Packing Box



Front wheel



Frame



Seatpost & Saddle



Charger



Removable battery



Pedals



Accessory bag (Frame bag)



Battery key



This accessory bag contains all the tools and accessories needed for assembling. It also doubles as a customized cycling frame bag, a free gift from Urtopia for your daily use!

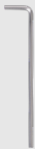

Allen key  
#4



Front wheel  
quick release device



15mm wrench

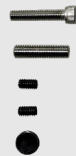

Spare parts

**from top to bottom:**

1. Big screw (for Smartbar)
2. Hex socket set screw (for seatpost fastener)
3. Side screws (for Smartbar)
4. Protective plug (for Smartbar)

# ASSEMBLE YOUR E-BIKE



**Assembling familiarizes yourself with your Urtopia.  
Engagement with your bike grows while you build.  
So roll up your sleeves and start, shall we?**

## 1. Before Assembling

---

- 1.1 First stand the e-bike securely. The included triangular bike-stand might be useful, but make sure it's firmly placed on the ground and the e-bike doesn't fall over.

### Notice

A protective padding is recommended to be put between the front fork ends and the ground.

**KEEP** the original package for future transport.



## 2. Install Front Wheel

- 2.1 Remove the following plastic protective parts: a pad between the braking pads inside the caliper, and a round plate on one side of the wheel hub.



**KEEP ALL** protective parts for future transport.

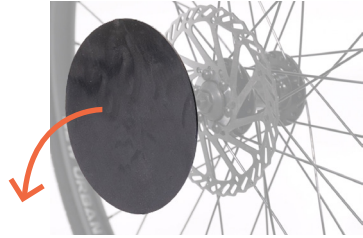

- 2.2 Before installing, make sure the bike is still secured in place as in 11. **NEVER** drop the fork ends to the ground to prevent permanent damage.



**!** Pulling the brake levers during installation may damage the caliper.



- 2.3 Insert the brake rotor between the brake pads, make sure they align and the wheel spins freely once installed.



### Notice

Make sure no friction between the rotor and brake pads.

- 2.4 Seat the wheel axle ends onto the fork dropouts fully to ensure riding safety.





- 
- 2.5** Take out the quick-release device, remove the nut and spring on one side, insert the skewer (with the other spring on) into the center hole of the axle, and put back the spring and nut as illustrated.



- 
- 2.6** Tighten the nut so that the lever meets resistance at 90° from the fork, then push it over to lock. Don't over-tighten the nut.



- 2.7** Check that the lever ends up in front of the fork and slightly ahead, so that it can be pulled back with ease to remove the wheel later on.

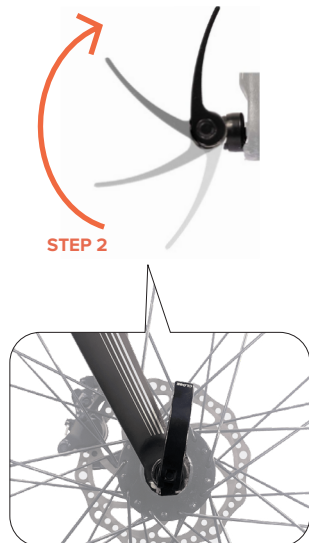

### 3. Install Seatpost

- 3.1** Find a cable connector inside the seatpost and the other one inside the seat tube. Connect them.



#### Notice

Notice the two white position marks on the seat-tube cable. The lower one indicates the maximum it should get out of the seat tube, and the upper one indicates the maximum it should reach inside the seat post.

- 3.2** Stash the cable inside the seatpost snugly.



- !** Pull and push the cables carefully when connecting. If the indicated positions are exceeded, internal electric circuits may be damaged.

- 3.3** Insert the seatpost into the seat tube, and take out the protective cover for the seat-tube screw hole. Use a 4mm Allen key to tighten the seat-tube screw and fasten down the seatpost at a desired height. Recommended torque: 7~9 N·m

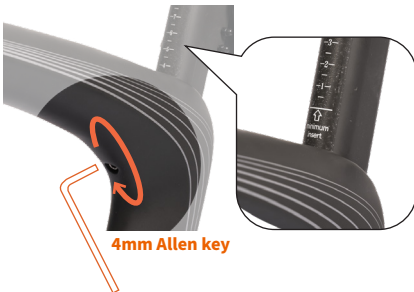

- !** The seatpost CANNOT rise above the minimum insert line. Otherwise, serious safety hazard may occur during riding.

## 4. Install Pedals

- 4.1 Use a 15mm wrench to tighten the left pedal counterclockwise.



- 4.2 Use the same wrench to tighten the right pedal clockwise.



## 5. Install the Battery

- 5.1 Press the power check button on the battery and make sure enough power left: blue is full, green is medium, red is low, and flashing red is critical.



- 5.2 Put the bottom of the battery into its compartment first, and then press it down fully.



### Notice

The battery can be charged while installed. Just remove the plug on the left side of the down tube.

## 6. Activate the Smartbar

**6.1** Download the Urtopia app and register your account.

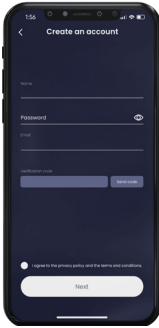

**6.2** After log-in for the first time,  
1. press any key on the Smartbar and scan the QR code shown on the display.  
2. Or connect the bike with the app manually via Bluetooth.



1. Smartbar display

2. Bluetooth connection

**6.3** Next, follow the on-screen guide and press the right button on the Smartbar a few times to record your fingerprint.

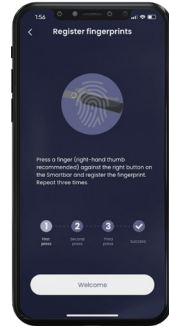

**Congratulations!**

Now say hi to your newborn Urtopia. It's time to hit the road--but make sure tires are pumped up well first!

# USE YOUR E-BIKE

## Smartbar Basics



①	<b>Fingerprint button</b>	<ul style="list-style-type: none"><li>· Press to unlock and power on (once fingerprint recorded)</li><li>· Long press for 2 seconds to unlock (if no fingerprint recorded. However, anti-theft features unavailable without fingerprint records)</li><li>· After unlocking, press for horn beeps</li><li>· Press and hold for voice control</li></ul>
②	<b>Control pad - Up</b>	<ul style="list-style-type: none"><li>· Press to speed up</li><li>· Long press for 2 seconds to enter Turbo mode (press either Up or Down key to exit Turbo mode)</li></ul>
③	<b>Control pad - Down</b>	<ul style="list-style-type: none"><li>· Press to speed down</li><li>· Long press for 2 seconds to enter Standby mode</li></ul>
④	<b>Control pad - Left</b>	<ul style="list-style-type: none"><li>· Press to indicate a left turn</li><li>· Long press 2 seconds to turn lights on/off</li></ul>
⑤	<b>Control pad - Right</b>	<ul style="list-style-type: none"><li>· Press to indicate a right turn</li><li>· Press and hold to enter Walk mode, release to exit</li></ul>

## LED Dot-Matrix Display



Current Speed,  
Battery, Speed Mode



Voice Control



Turn Indicator



Lock the Bike



OTA Update



Warning!



Fingerprint  
Recording

## Voice Commands

Press and hold the fingerprint/right button to activate Voice Control. Remove your finger to stop.

<b>Switch speed mode</b>	Speed up
	Speed down
	Speed 3 (Sport mode)
	Speed 2 (Comfort mode)
	Speed 1 (Eco mode)
	Speed 0 (Pedal mode)

<b>Lights on/off</b>	Lights on
	Lights off
	Turn on the lights
	Turn off the lights

<b>Turn left/ right</b>	Turn left
	Turn right

<b>Volume</b>	Volume 1
	Volume 2
	Volume 3

<b>Lock the bike</b>	Lock the bike
	Lock up

<b>Standby mode</b>	Go to sleep
	Power off

\* Movement alarm is activated **ONLY** in Lock mode.  
There is no alarm in Standby mode.



**RIDE: SAFE & FUN**

# BEFORE FIRST RIDE

## Check the Items Below Before Your First Ride

- Check if the tires are in good condition and the tire pressure is 50~85 psi / 3.5~6.0 bar. Make sure the front and rear wheel rotate smoothly without distortion. Make sure the spokes are not broken.
- Make sure the front wheel quick release is secure, and the tire is at the center of the front forks.
- Make sure the saddle, stem and handlebar are aligned centrally. Check if each screw is tightened.
- If you are riding at night, please make sure your bike is properly fitted with lights and reflectors. Please adhere to the relevant regulations.
- The bike is equipped with hydraulic disc brakes. Note that the left-hand lever actuates the front brake while the right-hand lever actuates the rear brake.
- Before riding, check whether the brake levers have any exposed core, or the brake wire skin is broken or peeled off.
- Do not modify or tune your bike. There is a risk of accident if you do so. Note also that modifications will void the warranty and may render the bike no longer approved for use on public roads.
- Do not perform any maintenance work on your bike unless you feel absolutely sure about it. If you have any doubt or question, contact Urtopia directly.
- Check the belt tension by pressing firmly down on it, in the middle, with your index. The deflection of the belt should be around 0.5cm to 1cm. Note that lubrication is not necessary.

## Symbol Definitions



A “notice” is important information that can help you avoid bike/property damage or extend the life of parts and the bike.









A “warning” statement indicates a hazardous situation that, if not avoided, could result in death, serious injury, or property damage.



A “danger” statement indicates a hazardous situation that, if not avoided, has a very high risk of death, serious injury, or property damage.

## Road Safety

-  Wear a bright colored and correctly fitted safety helmet that complies with international standards.
-  Wear bright, light-colored, fluorescent or reflective and well-fitted clothing, or a reflective belt, particularly at night or in poor light.
-  Wear personal protective equipment, for example, pads, gloves etc.
-  Choose a right type and size of bike for you.
-  Bike must be fitted with a warning bell and a rear red reflector.
-  Make sure the brakes are suitably adjusted and in proper working order, and can stop the wheels effectively.



- ⚠ Tires should be in good condition with clearly visible tread pattern and are properly pumped up.
- ⚠ Chain/belt should be suitably tight with no sign of damage.
- ⚠ Charge your battery fully before your first ride.
- ⚠ The front or side of the bike should be fitted with white reflectors and the pedals with amber reflectors.
- ⚠ Any articles carried while riding should be light and small.
- ⚠ The Urtopia Carbon E-Bike is not designed for off-road conditions. Please use with caution whenever on those surfaces.
- ⚠ Handlebar cannot affect the reaction of their vehicles to steering and braking.
- ⚠ Plan the journey in advance and make use of the bike tracks as far as possible.
- ⚠ Must not carry any passenger.
- ⚠ Must not carry animal or things which might obstruct your view or affect your balance/control of your bike, or get caught in the wheels/belt.
- ⚠ Must not enter a tunnel area, a control area or an expressway.
- ⚠ Must never be towed or hold on to a vehicle, or tow another bike or other vehicle.
- ⚠ Must not ride a bike in the opposite direction to traffic on road.
- ⚠ Do not lead any animal.
- ⚠ Do not wear earphones of any audio devices or use a mobile phone while riding.
- ⚠ Can not put the e-bike in a enclosed space of more than 80 degrees (Celsius and Fahrenheit), try to put in a cool, dry environment

# MAINTENANCE

## Pump Your Tires

Recommended tire inflation pressure: 50~85 psi / 3.5~6.0 bar.

## Maintain Your Carbon Belt

- Wash with water to remove debris.
- Acceptable temperature range for the CDN belt system is -4°F (-20°C) to +140°F (+60°C).
- Do not lubricate.
- This is a drive system – it is imperative to keep body parts and clothing away from the drive while in motion.

## Carbon Fiber Statement

1. Carbon fiber silk is a type of polymer fiber made from artificial chemical fiber with higher than average carbon content and manufactured via a series of rigorous and complex processes such as drawing, oxidation, carbonization and graphitization inside a furnace.
2. The carbon fiber used to manufacture an Urtopia Carbon E-Bike is composed of carbon fiber silk with high polymer resin which gives it a sticky quality that enables layers to be stuck to one another. After the hot molding process, its tensile strength can be up to 6~9 times stronger than an equivalent structure made of steel and its compressive elastic modulus is also higher, yet its weight being only one quarter of the steel equivalent.

## Electric -Assisted .....

You must turn on the battery to use the e-bike in Electric-Assisted mode.

In the Electric-Assisted model, power assist is triggered when you pedal forward, and power assist stop when you stop pedaling. In other words, power assist happens as long as you pedal. You don't need to pedal hard. All you need is to apply a light force to the pedals continuously to maintain the current flow. When you apply one of the brakes, power-assist will automatically stop, allowing the e-bike to slow down and stop. Power assist will turn itself off when the e-bike has reached the maximum speed of 25km/h.

## Recommended cleaning method .....

Do not use high pressure water streams to clean your e-bike, as water might seep inside the motor or the wiring compartment and cause rusting of electric parts or short circuits. Please use damp cloth with neutral detergent to clean the bike body. Do not use alkali-based or acid based detergent such as rust cleaners as it may result in damage and/or failure of the bike body.

Avoid parking your e-bike outside when there is rain or snow. At the end of a trip where there was rain or snow, bring the e-bike inside and use a clean, dry towel to eliminate any wetness.

During daily use, please keep the controller clean and dry, keep it away from water, vibration and contamination, otherwise the controller may be damaged.

# BATTERY

## Basics .....

Your e-bike is powered by a modern lithium-ion (Li-ion) battery. They offer a large capacity (range) with the lowest weight. In addition, they do not suffer from memory effect.

Your battery is protected by a modern management system against overcharging and short-circuits.

















The removable battery pack can be charged with or without a bike. Locate the charging port and plug the connector into the charging port to start charging.









## Battery Safety

---

-  Check the battery before using the bike for the first time.
-  Recharge the battery after each ride. Always charge it back to full so it is ready to travel the full range next time you ride.
-  If the battery is completely empty, charge it as soon as possible. Storing a depleted battery can lead to permanent loss of range or loss of battery life.
-  Used batteries should not be thrown in the domestic waste. You can return used batteries to a recycling facility or to an authorized dealer. Defective or used batteries, battery packs or single cells must be collected separately and disposed of in an environmentally friendly manner.
-  Letting a battery charge unattended increases the risk that a charging problem will go undetected and lead to component damage or a fire hazard. Always charge your battery where you can monitor it.
-  Only use a battery charger designed for your bike and supplied by Urtopia.
-  Letting the charger's plug contact metal objects could cause a power discharge (a spark), which could injure you or create a fire hazard.
-  Pay attention to waterproofing to prevent the battery pack from being exposed to excessive water.
-  E-Bikes are prohibited from overloading. When the load is too large, the running current will increase, and the cruising range will be reduced or there will be a power outage.
-  When the battery pack needs to be stored for a long time, please charge the battery pack to a half-charged state, place it in a dry and ventilated place, and charge it with the charger every three months.
-  Never use the battery upside down.
-  No obvious loss or deformation of the battery pack.
-  It is forbidden to use battery packs in series and parallel.
-  It is forbidden to use cracked or damaged batteries or BMS battery packs.
-  If the battery has abnormal noise, odor, damage, deformation, discoloration, melting, heating, water etc., stop charging immediately and place the battery in an open place.

## Safety Alerts

---

-  Keep away from sources of fire and heat, and it is strictly forbidden to put the battery into a fire.
-  It is strictly forbidden to disassemble or repair the battery pack by yourself.
-  Severe vibration, shock and extrusion are strictly prohibited.
-  Keep away from children.
-  Never open the battery housing, which will void the warranty and can result in battery damage. It can also expose you to caustic substances and electrical shock or it could create a fire hazard, which can lead to serious injury or death.
-  Never charge a battery which you suspect is damaged or know is broken, and do not use it.

# SPECIFICATIONS

## General

<b>Weight</b>	Medium 15.2 kg, Large 15.6 kg
<b>Max. permissible total weight</b>	Max. 240 lbs. (110 kg)
<b>Sizes</b>	Medium, Large
<b>Body material</b>	Carbon fiber (frame, fork, handlebar, seatpost)
<b>Brakes</b>	Front & rear dual-piston hydraulic disc
<b>Transmission</b>	Gates Carbon Drive™ CDN™ belt (up to 30,000 km)
<b>Integrated lights</b>	StVZO headlight; Advanced Rear Early-indication System (ARES)
<b>Wheels</b>	700C (ISO 622 mm BSD), inner rim 19 mm
<b>Tires</b>	Kenda Kwest 700 × 35C (35 mm / 1.4") (30~45 mm compatible)

## Motor

<b>Power modes</b>	Pedal, Eco, Comfort, Sport, Turbo
<b>Top speed (assisted)</b>	20 mph (32 km/h), US version; 16 mph (25 km/h), EU version

## Removable Battery

<b>Capacity</b>	352.8 Wh
<b>Cell</b>	Samsung Li-ion

## Range

<b>Eco mode</b>	Up to 100 km / 62 miles
<b>Comfort mode</b>	Up to 60 km / 37 miles
<b>Sport mode</b>	Up to 40 km / 25 miles

## Temperature

<b>Charging</b>	0°C / 32°F ~ 40°C / 104°F
<b>Operation</b>	-10°C / 14°F ~ 50°C / 122°F
<b>Storage</b>	-10°C / 14°F ~ 30°C / 86°F

## Charger

<b>Charging time</b>	2.5 hrs quick charge
<b>Input Voltage</b>	100~240 V AC
<b>Max. Output Voltage</b>	42 V DC
<b>Max. Output Current</b>	4 A

# TAKE GOOD CARE

## Warranty

Urtopia offers a 2-year warranty for its e-bikes against all manufacturing defects, starting from the date the initial owner receives it. This warranty covers the bicycle frame, the battery and all original components. This warranty does not cover ordinary wear & tear, improper assembly or follow-up maintenance, or installation of parts or accessories and defects or damage resulting from accident, abuse, misuse, abnormal use, improper storage or neglect. Urtopia will replace any component that is deemed to be defective or damaged under this warranty.















Claims under this warranty must be made directly to the place at which you purchased your Urtopia and proof of purchase is required. Before making a warranty claim, we suggest you contact us at [support@newurtopia.com](mailto:support@newurtopia.com) and upload photos or videos of the damaged product first. Urtopia after-sales service will help you and there may be a simple fix for the problem.

Detailed warranty terms can be found on Urtopia official website: <https://newurtopia.com/pages/warranty>.

## Disclaimer

Under no circumstances, including, but not limited to negligence, shall Urtopia be liable for any damages, including but not limited to special or consequential damages that result from the use of, or the inability to use, the Urtopia Carbon E-Bike and/or any other products or materials referred to in this manual, even if Urtopia has been advised of the possibility of such damages. Applicable law may not allow the limitation or exclusion of liability or incidental or consequential damages, so the above limitation or exclusion may not apply to you.

## Warnings

-  Do not touch the disk of the front and rear brake while it is rotating or directly after braking. This could result in injury or burns.
-  Do not remove the battery cells, and always contact Urtopia regarding any battery issues.
-  Always ride with care – turning and braking suddenly may cause accidents.
-  Do not modify or tamper with the bike's motor or integrated computer systems. Modifying the bike in any way will void your warranty and can lead to accidents resulting in injury or death.
-  International convention dictates that the left brake lever controls the front wheel brake while the right brake lever controls the rear wheel brake. In the UK & Japan, however, the reverse is true.
-  Riding in the city can be hazardous. Failure to wear a helmet when riding may result in serious injury or death.
-  Never ride with headphones or talk on the phone while riding.
-  Never ride in a situation where you are not able to fully control the bike.
-  The Urtopia Carbon E-Bike is not suitable for towing trailers of any sort.
-  Take care when riding in wet and slippery conditions. Ride slowly and gently apply force to the brakes to accommodate a longer stopping distance.
-  Ride at an appropriate speed, in accordance with the terrain, your riding capabilities and local government regulations.
-  Disc brakes can produce significant stopping power and may behave differently from other bike brake systems. Please familiarize yourself with the brakes before your first ride.
-  Always make sure your lights are working properly and not covered or obscured. We recommend using lights in all conditions for maximum visibility.
-  This bike is made for riding in the city. Do not use it for racing, mountain biking or for any other form of non-urban cycling. Understand your bike and its intended use. Choosing the wrong bike for your purpose can be hazardous. Using your bike the wrong way is dangerous.

- ⚠** Inspection and maintenance are important to the safety and longevity of your bike. Regularly check the brakes, tires, steering, and wheel rims. Any part of a poorly maintained bike can break or malfunction, leading to an accident resulting in serious injury or death.
- ⚠** Your bike must comply with your country's legal requirements when riding on public roads in all conditions, including bad weather, night time, dusk or dawn. Many countries require specific safety devices. It is your responsibility to familiarize yourself with the laws of the country where you ride and to comply with all the applicable laws, including properly equipping yourself and your bike as the law requires.
- ⚠** Failure to confirm compatibility, properly install, operate and maintain any component or accessory can result in serious injury or death. Do not modify your bike frame or components in any way. Modifications can cause damage leading to an accident that can result in severe injury or death. Incompatible accessories or improper mounting of accessories can adversely affect the performance of your bike and may be unsafe.
- ⚠** As with all mechanical components, bikes are subject to wear and tear, as well as high stresses. Different materials and components may fatigue in different ways. Make sure you have replacement parts available for components which are easily worn or damaged, e.g. tires and brake pads. If the designed life of a component has been exceeded, it can suddenly fail, possibly causing injuries to the rider. Any form of crack, scratches or change of coloring can indicate that the life span of a component has been reached and that it should be replaced.
- ⚠** Please note all product-specific requirements for any third party products you add to the bike. Child and baggage carriers add weight and raise the center of gravity, affecting balance and bike handling. If you lose control, you and any child passengers can be severely injured or killed.
- ⚠** Do not fit a child seat to the e-bike, unless recommended and installed by Urtopia. Doing so may result in injury or death.
- ⚠** The A-weighted emission sound pressure level at the driver ears should be less than 70 dB(A).
- ⚠** For composite components impact damage may be invisible to the user, the manufacturer shall explain the consequences of impact damage and that in the event of an impact; composite components should either be returned to the manufacturer for inspection or destroyed and replaced.

## Assembly Instructions

Name of clamp bolts	Standard torque /N-m
Smartbar and fork clamp bolt	6~8 N-m
Saddle	12 N-m
Seat post	7~9 N-m
Front wheel	Quick release
Rear wheel	15~18 N-m

## Ubricate

Do not over lubricate. If oil gets on the wheel rims or the brake shoes, it will reduce brake performance and a long distance to stop the bicycle will be necessary. Injury to the rider or to others can occur.

-Using soap and hot water, wash all oil off the wheel rims, the brake shoes, the pedals, and the tires. Rinse with clean water and dry completely before you ride the bicycle.

-Using a light machine oil (20W) and the following guidelines, lubricate the bicycle:

<b>Pedal</b>	Every 6 months.	Put 4 drops of oil where catch pedal axle goes into the pedal
<b>B.B.</b>	Every 6 months.	Contact a professional technician
<b>Motor</b>	Every 1 year.	Contact a professional technician

**Dedicated to the passionate ones.  
See you down the road.**



[www.newurtopia.com](http://www.newurtopia.com)